

In this day and age practically everyone is armed with a cell phone. Some of these smart phones not only work as a cell phone but have enough processing power that they are potentially compete with a notebook computer for surfing the web; with a digital camera for taking pictures; with an MP3 player for listening to music; with hardcopy books by allowing downloaded electronic version; with cash and credit cards for paying bills – the possibilities are endless.

All these applications for the cell phone have put extreme efficiency requirements from a systems point of view. Since the cell phone is a portable device powered by a single Li-ion cell, every aspect of the cell phone has to be optimized from a power point of view. This application note will focus on optimizing power to the power amplifier which is the heart of a cell phone. In the past most of the power amplifier were powered by a low dropout regulator. But now to keep up with the current applications, the power amplifiers have become real power hungry to maintain a certain signal-to-noise ratio. In some GSM (global system for mobile system) handsets, the power amplifier can draw up to approximately 40% of the stored battery energy.

GSM900 is widely used in most parts of the world and uses 890MHz to 915MHz to send information to the base station (uplink) and 935MHz to 960MHz to receive information from the base station (downlink). This allows 124 RF-channels spaced at 200kHz. In a typical GSM network, the handset does not communicate with the base station at full RF power level all the time as seen from the below GSM900 probability density function which shows probability of use vs transmitted RF power.

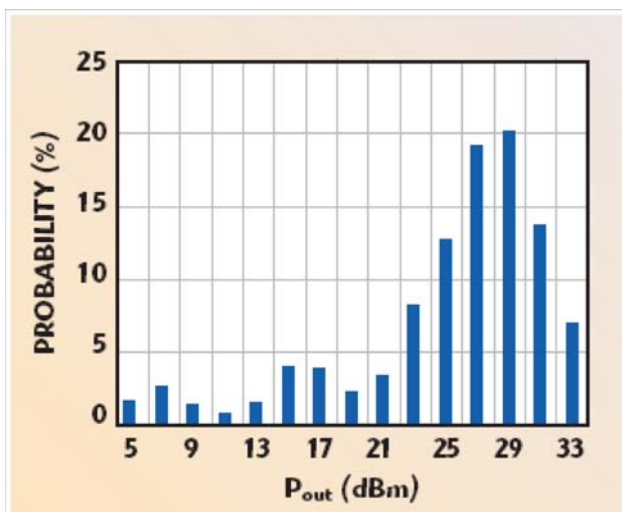

FIGURE 1. CLASS 4 GSM PROBABILITY DENSITY

P_{OUT} in Figure 1, is the RF power generated by the power amplifier (PA) for data communications and is usually directly proportional to the PA input voltage. This very requirement forms the basis for this application note for using the ISL9109 DC/DC buck regulator as a power supply for the power amplifier. Due to cost reason, traditionally PA manufacturers have used a low dropout linear regulator to power the PA, but now are migrating towards using a buck regulator to optimize battery life. The efficiency of an LDO is V_O/V_{BAT} which for a 1.8V_{OUT} from a fully charged 4.2V Lithium Ion battery is approximately 43%. On the other hand, the ISL9109 buck regulator under the same test conditions is approximately 89% efficient.

The schematic in Figure 2 shows a complete PA buck regulator power supply. The input voltage on the ISL9109 can be from 2.7V to 5.5V, but in this case the input is limited by the voltage range of a single Li-ion cell which is typically 3V to 4.2V. The part has internal synchronous MOSFETS which can support 1.5A continuous load current and switches at 1.6MHz and still achieves 95% efficiency. The higher switching frequency saves board space by requiring smaller inductor and capacitor on the output. The part also has an EN pin which allows a nanoamp shutdown drawing only 50nA. It also has a mode pin which allows PFM mode to achieve higher efficiency at light loads (<50mA) by tying this pin to the input supply; or PWM mode by connecting this pin to ground. The constant PWM mode results in constant switching frequency of 1.6MHz and is independent of load variation. The part also has a STBY pin which allows the output voltage to reach steady state in less than 60μs. The part enters this mode by asserting STBY pin approximately 1ms before the part is Enabled. This mode can easily be programmed with a simple RC network or a pre-transmit signal from the baseband chip to pull the Stby pin high approximately 1ms before enabling the part. This feature allows keeping the ISL9109 in nanoamp shutdown mode until the PA is ready to transmit data, hence conserving battery life. Since the PA transmits at different output voltages, this can easily be achieved by connecting a resistor R₃ from FB to a DAC output of 0V to 1V from the baseband chip. The relationship between PA output and DAC voltage is given in Equation 1 and plotted in Figure 3. It can be seen that V_{PA} is 3.4V when V_{DAC} = 0V and 1.5V when V_{DAC} is 1V. Equation 1 can easily be used to program different output voltages from a different DAC voltage by using different values for R₁, R₂, and R₃. Figure 4 shows the efficiency for 1.8V_{PA} from V_{BAT} = 2.7V and 3.3V; Figure 5 shows the start-up time for V_{PA} = 1.5V to be around 50μs; Figure 6 shows the transient response for a 0A to 1A load step on the PA when V_{BAT} = 3.6V.

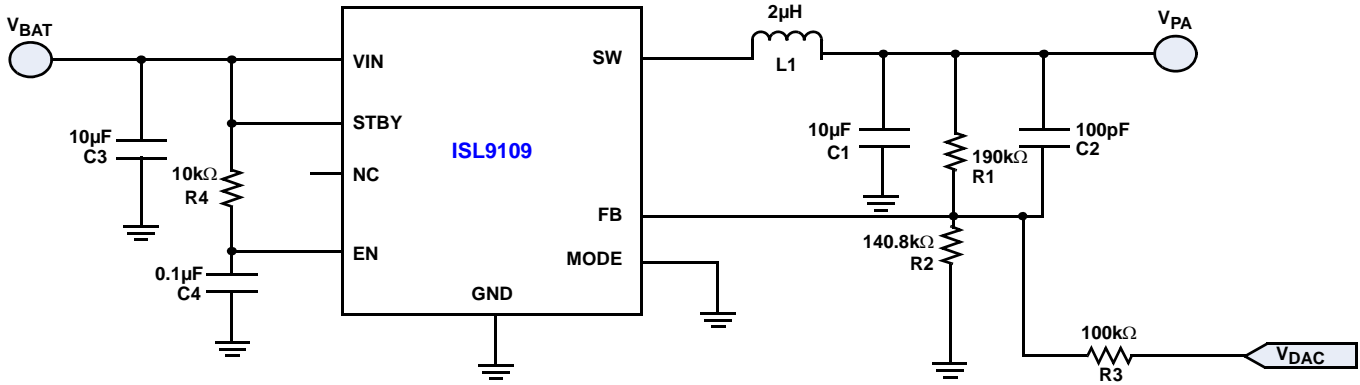

FIGURE 2. ISL9109 PROGRAMMABLE PA POWER SUPPLY SCHEMATIC

$$V_{PA} = V_{FB} \left(1 + \frac{R_1}{R_2} + \frac{R_1}{R_3} \right) - V_{DAC} \left(\frac{R_1}{R_3} \right) \quad (\text{EQ. 1})$$

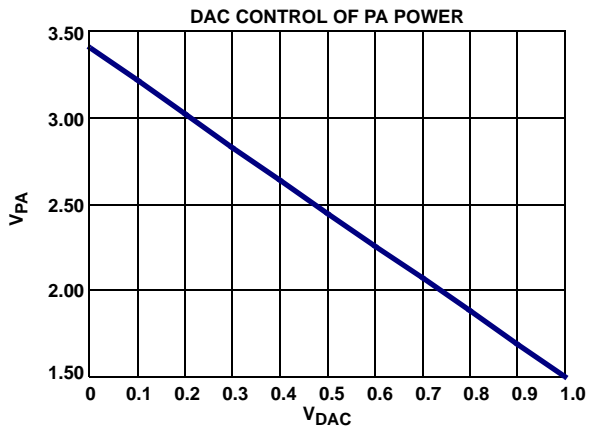

FIGURE 3. V_{PA} vs V_{DAC}

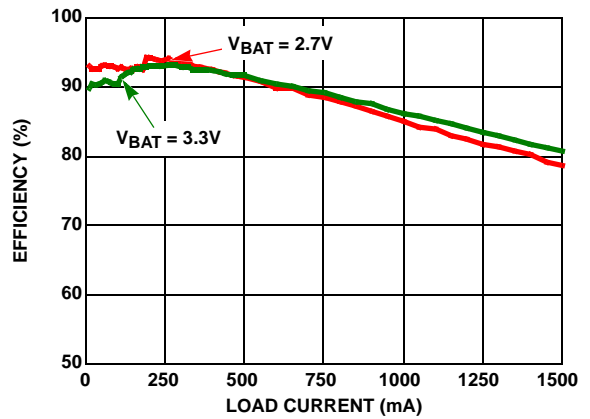

FIGURE 4. ISL9109 TYPICAL APPLICATION SCHEMATIC EFFICIENCY

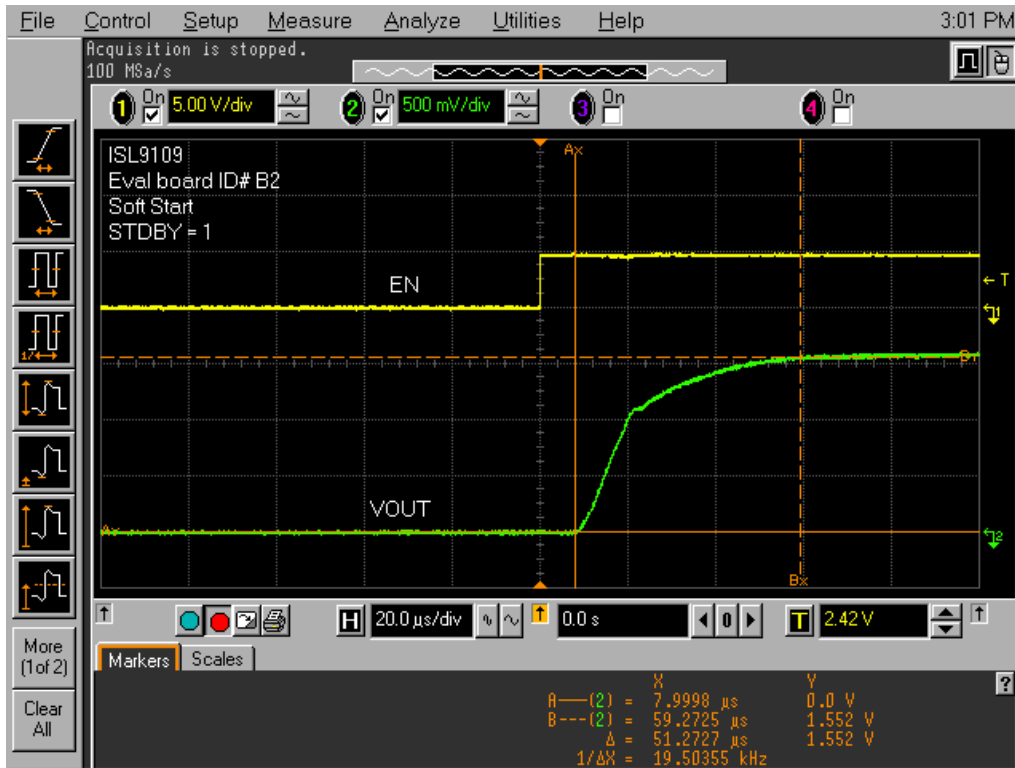

FIGURE 5. ISL9109 $V_{PA} = 1.5V$ START-UP WAVEFORM

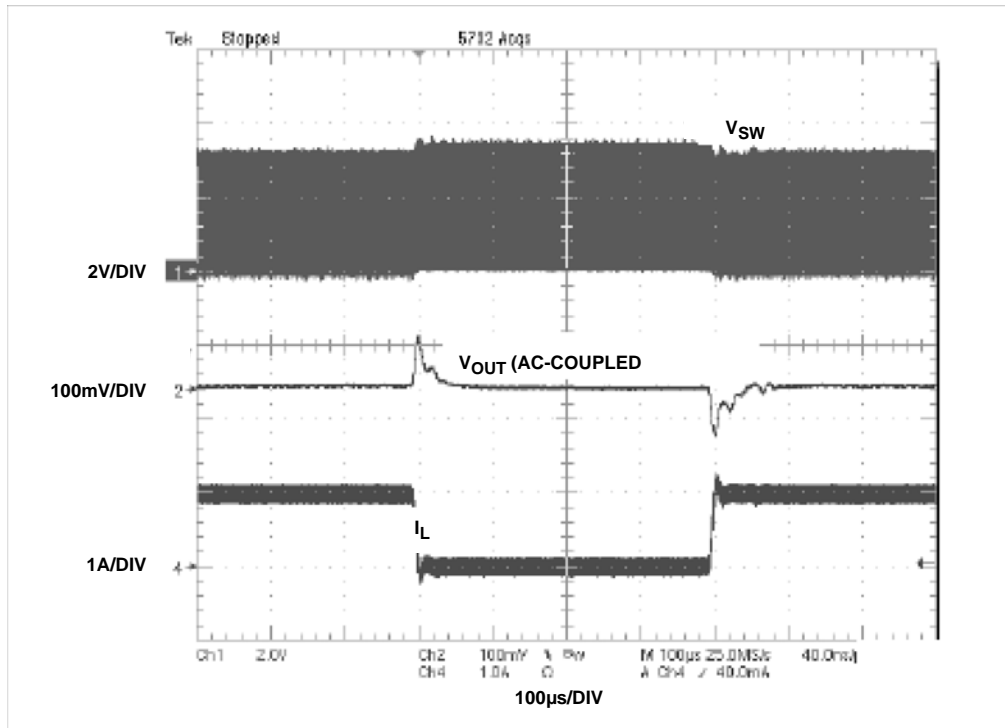

FIGURE 6. V_{PA} TRANSIENT RESPONSE AT 1.5V FOR A 0A TO 1A LOAD STEP

ISL9109 Powers Anadigics AWE6174 Power Amplifier*

Figure 7 shows the ISL9109 providing power to Anadigics AWE6174 Quad-Band GSM/GPRS/Polar Edge Power Amplifier. Some other suppliers have a buck regulator and an integrated bypass switch which they turn-on when the baseband chip decides to transmit at full power. The purpose for having this bypass switch is to allow the input battery voltage to drop further down and still be able to provide 3.4V on the output which is the PA voltage for transmitting at 33dbm. The $r_{DS(ON)}$ of the bypass switch is usually 75mΩ which is much less than the $r_{DS(ON)}$ of the high side buck regulator and the DC resistance of the buck inductor. For the ISL9109 the $r_{DS(ON)}$ is 150mΩ and the inductor resistance is 100mΩ. The AWE6174 power amplifier does not benefit from having an internal bypass

switch since it has a low dropout LDO in parallel which the baseband chip enables when it wants to transmit at full power. To empirically see the advantage of using a buck regulator over the internal LDO, efficiency data was taken on the AWE6174 PA operating at certain dBm in GSM 900 mode powered with the ISL9109 vs with its internal low dropout regulator as shown in Figure 8. It can be seen from Figure 9 that at 29dBm and 27dBm where the handsets spend most of its time (~40%), the average current consumption weighted by PDF is reduced by 40% at the former and by 23% at the latter power level. This average input current reduction results in about 20% gain in talk time from 5 hours to 6 hours for 850mA-Hr battery in a typical phone application.

*Data provided by Anadigics

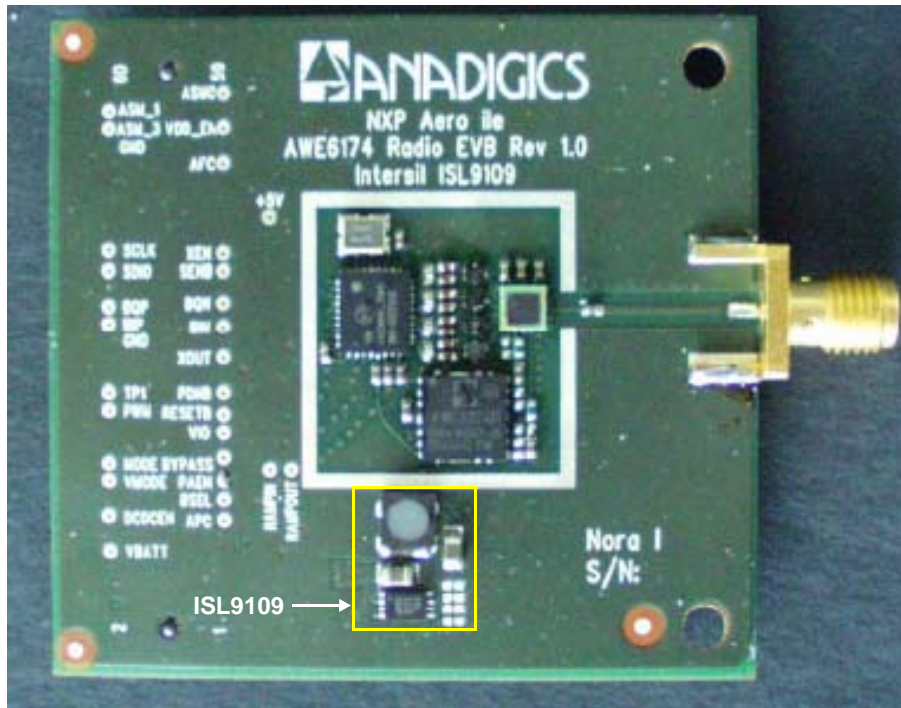

FIGURE 7. ISL9109 POWERS ANADIGICS AWE6174 PA

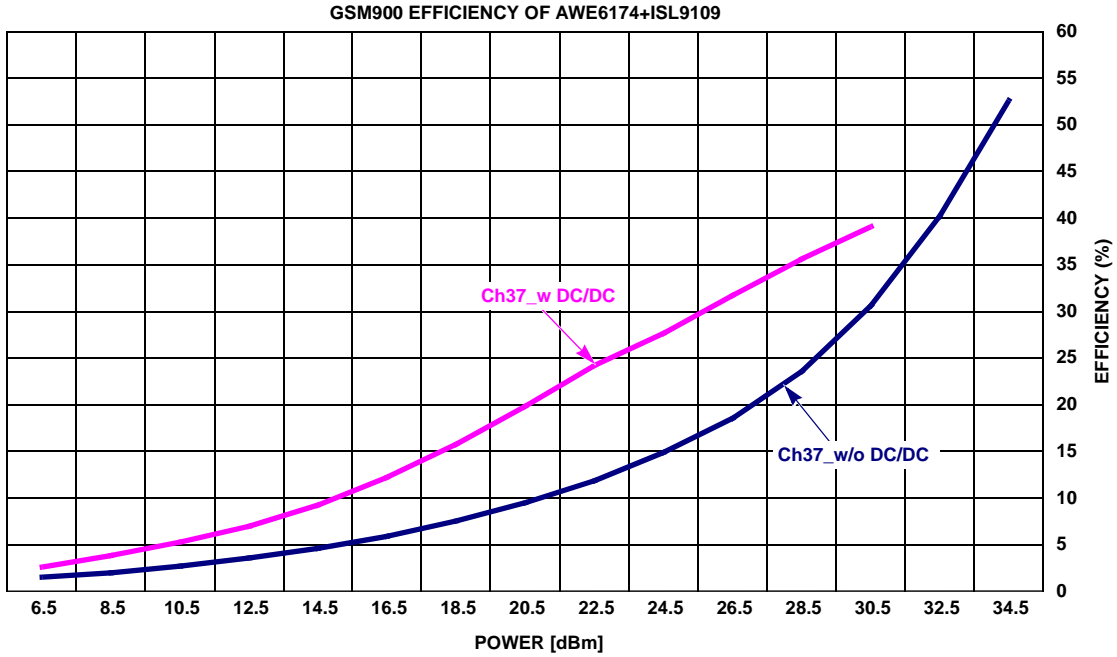

FIGURE 8. OVERALL SYSTEM EFFICIENCY FOR ISL9109 vs LDO

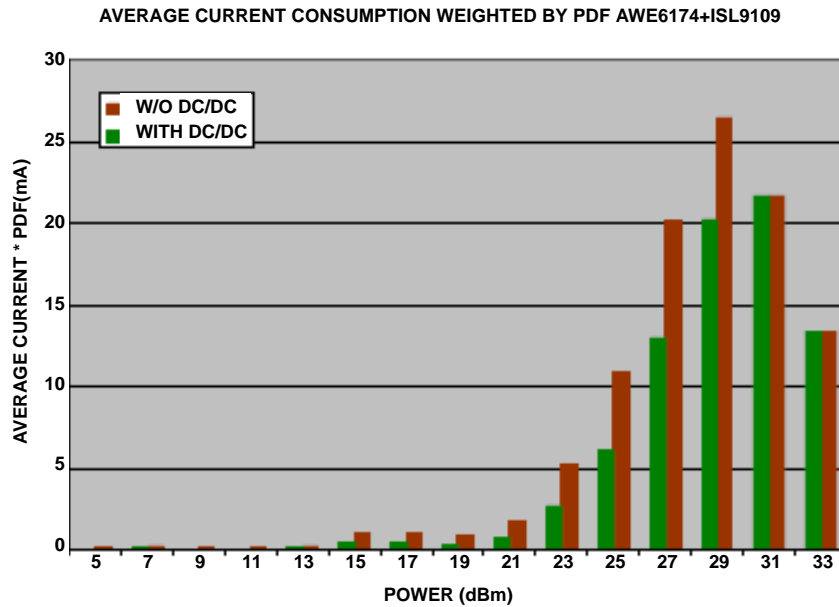

FIGURE 9. AVERAGE INPUT CURRENT REDUCTION BY USING ISL9109 INCREASES TALK TIME BY 20%

Intersil Corporation reserves the right to make changes in circuit design, software and/or specifications at any time without notice. Accordingly, the reader is cautioned to verify that the Application Note or Technical Brief is current before proceeding.

For information regarding Intersil Corporation and its products, see www.intersil.com